



PE-5000 DUCT STATIC PRESSURE SENSING ELEMENT

DESCRIPTION

Model **PE-5000** units are insertion-type primary duct pressure sensing elements designed to achieve pressure signal accuracy and stability. The accuracy and low signal-to-noise ratio of the output is made possible by the placement of multiple sensing ports along the length of the element and the averaging effect of the internal manifold.

Installation costs are low; the units are simply installed through a small cutout in new or existing ductwork. Their low installed costs make them very economical for multiple branch variable air volume (VAV) duct systems where indication and fan capacity control may be based on the lowest (most economical) pressure of the multiple static pressure points.

Each element is furnished complete with mounting hardware, sealing gaskets, and signal connection fittings.

Features

- Low signal-to-noise ratio
- Multiple static pressure sensing ports along the length of the element
- Averaging internal manifold
- $\pm 2\%$ accuracy throughout the velocity ranges of 100 fpm and over
- Standard construction is 6063-T5 aluminum with anodized finish
- Available in optional corrosive resistance materials including Type 316L stainless steel, Hastelloy C-22, and Type 1 PVC
- Standard elements can be operated (in air) continuously in temperatures up to 350°F or intermittently in temperatures up to 400°F
- All types of elements can be operated in humidity ranges of 0 to 100%
- Standard elements have good salt air and mild acid resistance; excellent solvent and aromatic hydrocarbon resistance

PE-5000 Technical Specifications

1. Accuracy

Within 1% of actual duct static pressure

2. Operating Velocity Range

100 to 10,000 fpm

3. Material

6063-T5 anodized aluminum (standard)

Type 316L stainless steel (optional)

Hastelloy C22 (optional)

Type 1 PVC (optional)

Note

Other corrosive resistant materials are available. Consult factory for further information.

4. Temperature

Aluminum Elements

350°F continuous operation (in air)

400°F intermittent operation (in air)

Stainless Steel Elements

1600°F continuous or intermittent operation (in air)

Hastelloy Elements

900°F continuous or intermittent operation (in air)

PVC Elements

120°F continuous operation and 170°F intermittent operation (in air)

Note: Corrosive resistant element maximum operating temperatures vary greatly with the concentration of the media in the process stream. Consult factory for further information.

5. Humidity

All Elements

0 to 100% non condensing

6. Corrosion Resistance

Aluminum Elements

Good salt, air, and mild acid gas resistance; excellent solvent and aromatic hydrocarbon resistance

Stainless Steel Elements

Good for sulfates, phosphates and other salts, as well as reducing acids such as sulphurous and phosphoric

Hastelloy Elements

Excellent resistance to strong oxidizers such as ferric and cupric chlorides, chlorine, formic and acetic acids, acetic anhydride, and salts.

PVC Elements

Excellent acid and alkalis resistance

7. Instrument Connections

Aluminum Elements

1/4" compression, suitable for use with thermoplastic or copper tubing; thermoplastic tubing requires the use of tubing inserts, which are supplied with the fittings

Stainless Steel and Hastelloy Elements

1/8-27 Female NPT

PVC Elements

1/8-27 Female NPT

PE-5000 Resistance to Airflow

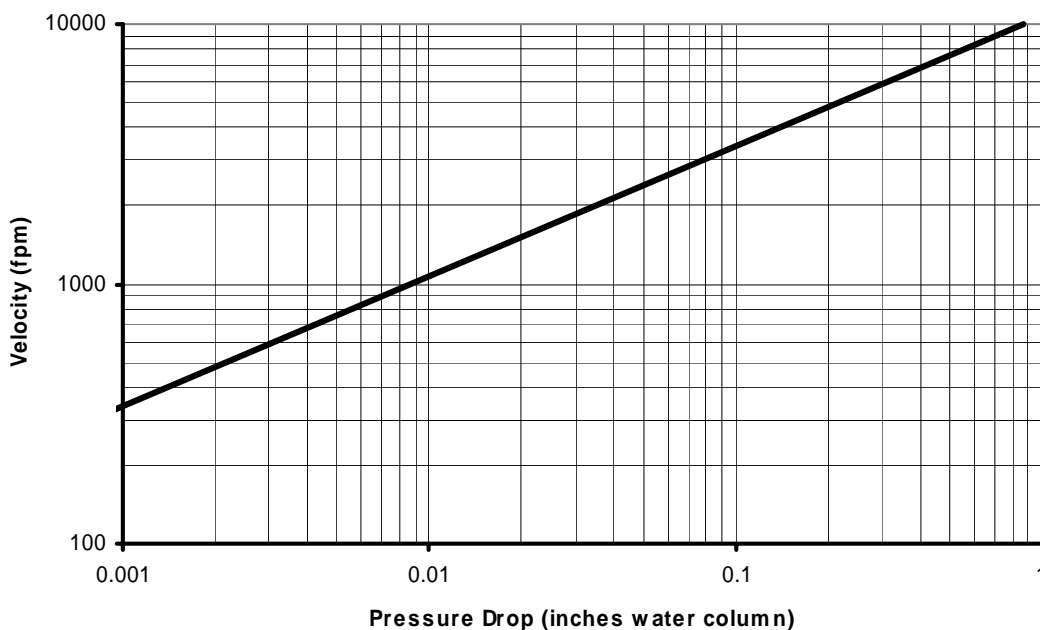

PE-5000 Dimensions

Aluminum Elements

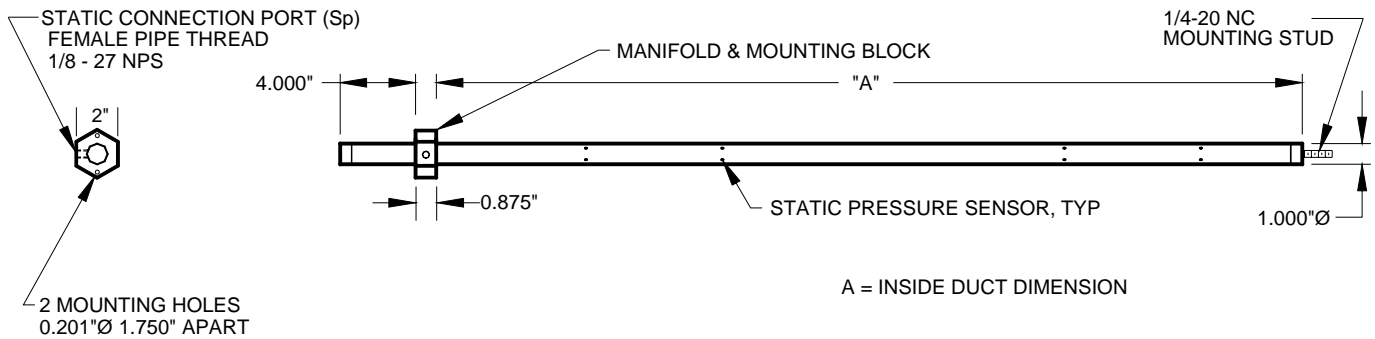
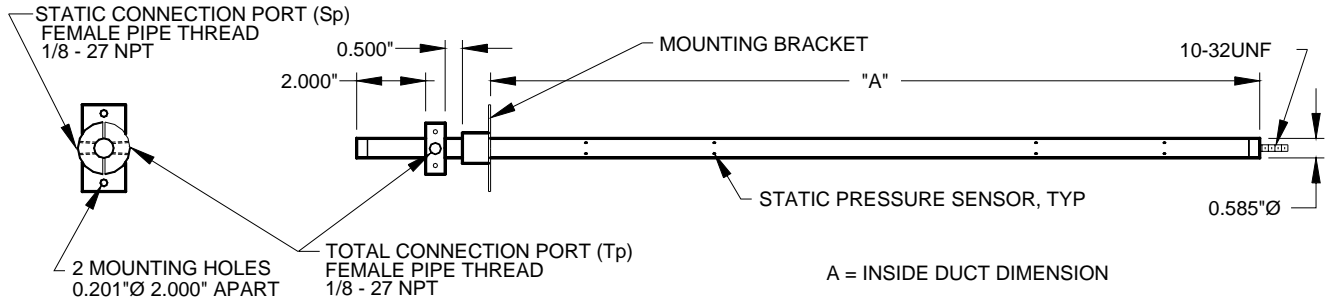

Note: The 0.585 inch diameter probe is used for elements up to 36 inches long and the 1 inch diameter probe is used for elements greater than 36 inches long.

PVC Elements

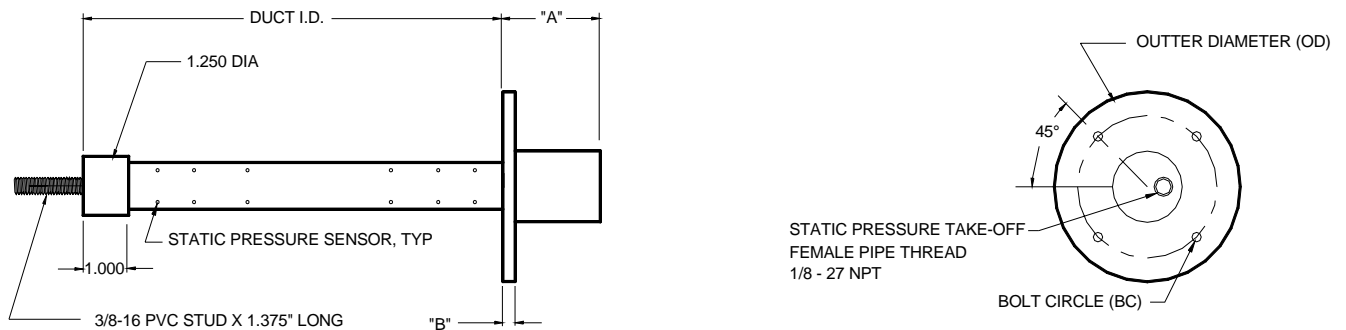

Dimension	Standard Flange (inches)	Optional 150# Flange (inches)
A	2.000	2.500
B	0.250	0.750
OD	4.000	5.000
BC	4-0.201" Diameter Holes on 3.000" BC	4-0.625" Diameter Holes on 3.880" BC

PE-5000 Dimensions (Continued)

Stainless Steel, Hastelloy, and Other Corrosive Resistant Elements

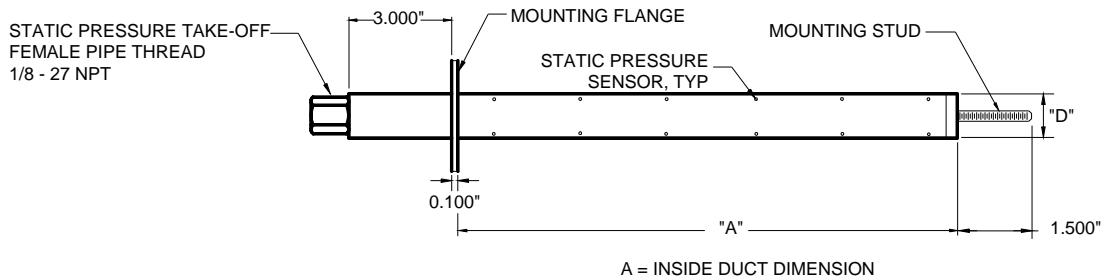

STANDARD MOUNTING FLANGES

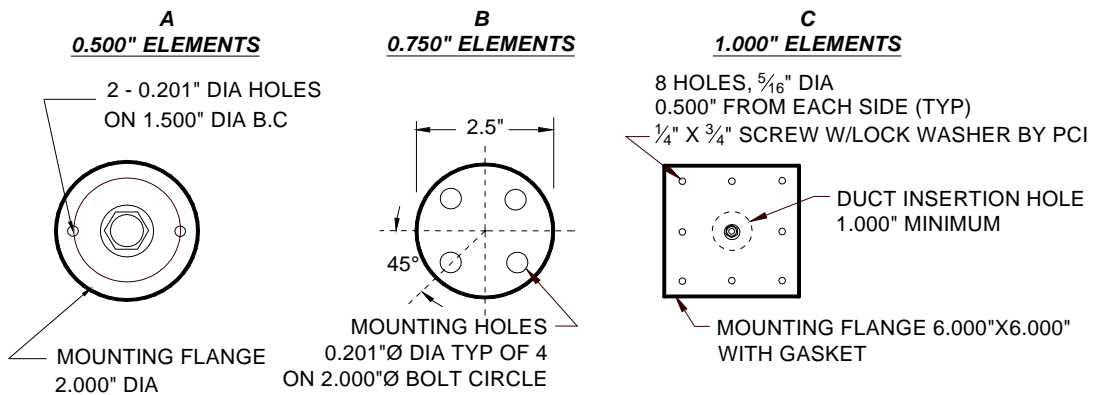

OPTIONAL MOUNTING ARRANGEMENTS

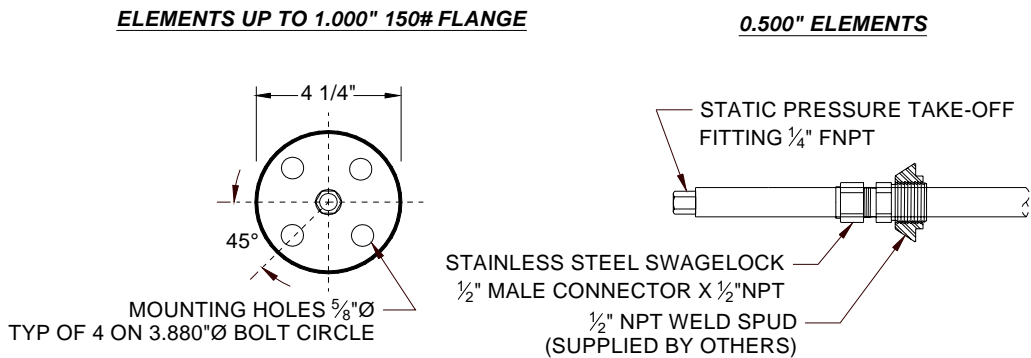

Element Dimensions		Standard Mounting Flanges	Mounting Stud
"A"	"D"		
0 - 24"	0.500"	A	1/4-20 NC
25 - 60"	0.750"	B	3/8-16 NC
Over 60"	1.000"	C	3/8-16 NC

PE-5000 Element Arrangement

RECTANGULAR CONFIGURATION

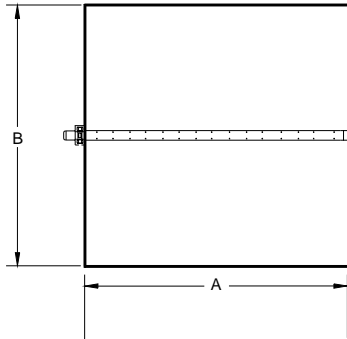

CIRCULAR CONFIGURATION

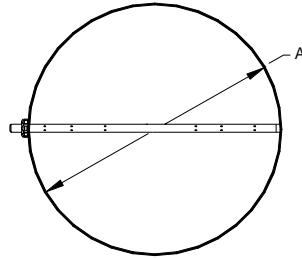

OVAL CONFIGURATION

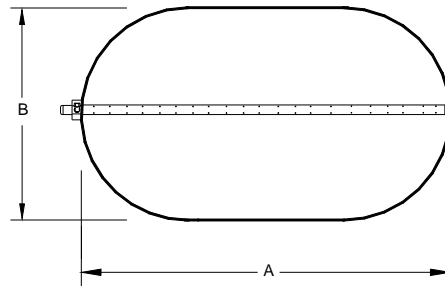

Notes:

A = Inside duct dimension (element length side)
 B = Inside duct dimension (element mounting side)

PE-5000 Minimum Installation requirements

The elements may be installed in any duct configuration. However, the accuracy of the installation is dependent on the flow conditions in the duct. The minimum installation requirements for the elements based upon a uniform velocity profile approaching the duct disturbance for flow rates less than 2,500 fpm are shown below. Add one duct diameter to the installation requirements shown below for each additional flow rate of 1,000 fpm. These are not ideal locations. It is always best to locate the elements as far as possible from all duct disturbances, with upstream disturbances being the most critical consideration.

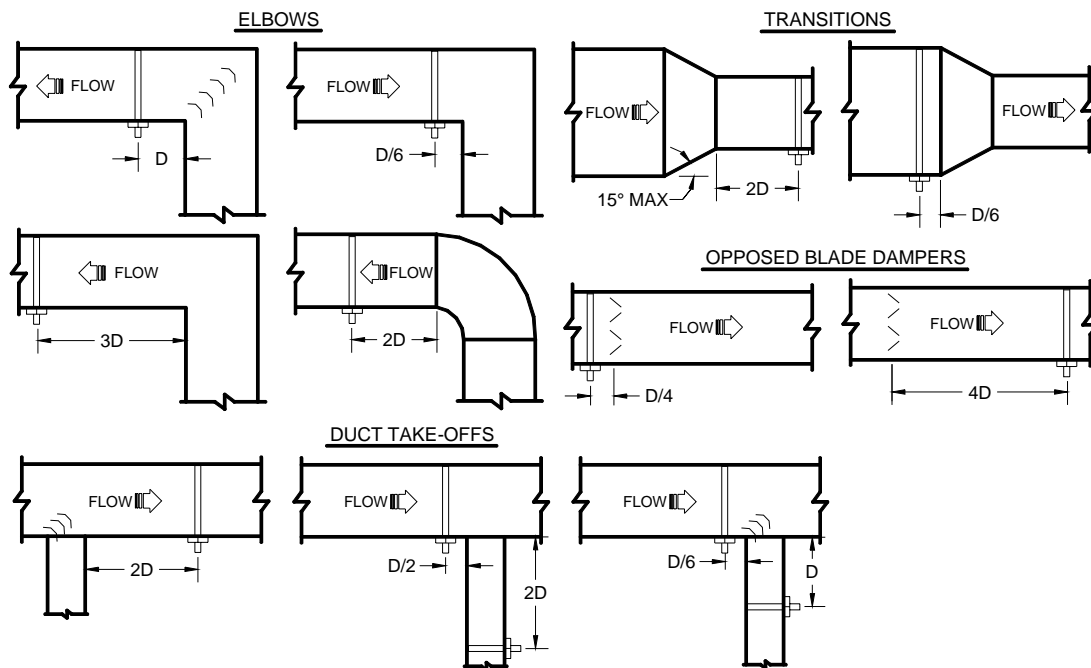

Notes:

Round Ducts:

D = Duct diameter

Rectangular Ducts:

$$D = \sqrt{\frac{4HW}{\pi}}$$

H = Duct height

W = Duct width



PE-5000 Ordering Information

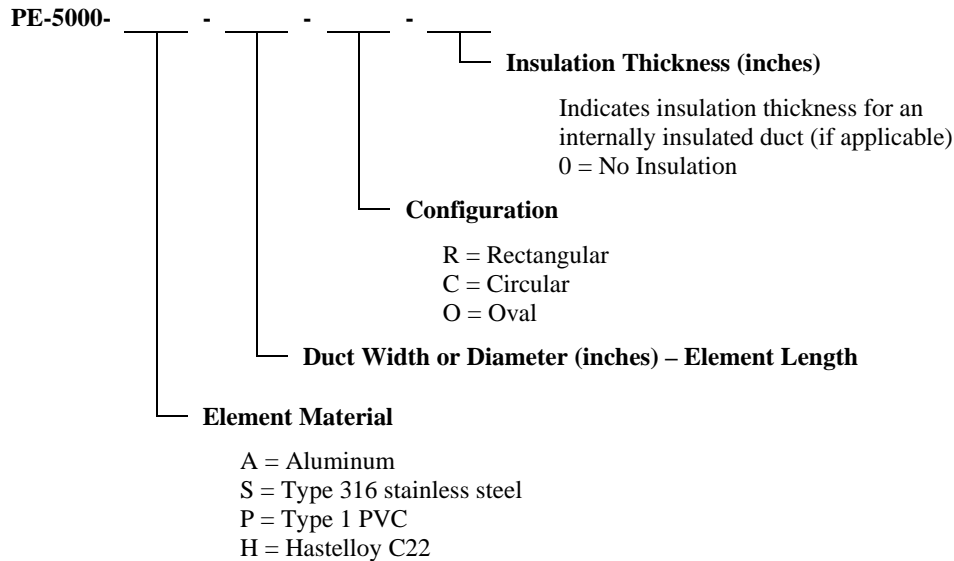

PE-5000 Specification Guide

Duct Static Pressure Sensing Elements

1. Provide where indicated and/or scheduled duct static pressure sensing elements capable of continuously monitoring the fan or duct air volumes they serve.
2. Each element shall be designed and built to comply with, and provide results in accordance with, accepted practice for duct system traversing as defined in the ASHRAE Handbook of Fundamentals, AMCA publication #203, as well as the Industrial Ventilation Handbook. The number of sensing ports on each element, and the quantity of elements utilized at each installation, shall comply with ASHRAE Standard #111 for equal area duct traversing.
3. Each element shall be of a dual integral chambered design. Each duct static pressure sensing element shall contain multiple static pressure sensing ports placed along the leading edge of the cylinder. The static pressure chamber shall incorporate dual offset static taps on opposing sides of the averaging chamber, so as to be insensitive to flow angle variations of as much as ± 20 degrees in the approaching air stream.
4. The duct static pressure sensing elements shall be capable of producing steady, non-pulsating signals of true static pressure, with an accuracy of $\pm 1\%$ of duct static pressure. Signal amplifying sensors requiring flow correction (K factors), or field calibration are not acceptable.
5. The duct static pressure sensing traverse elements shall not induce a measurable pressure drop, greater than .18" at 4000 feet per minute. The units shall have a self-generated sound rating of less than NC40 and the sound level within the duct shall not be amplified, nor shall additional sound be generated.
6. Where duct static pressure sensing elements are located outside of the manufacturer's published installation guidelines the manufacturer shall be consulted, and approve of any special configurations, such as air equalizers and/or additional and strategically placed measuring points, as may be required.

Installation Considerations

1. Duct static pressure sensing elements shall be installed in strict accordance with the manufacture's published requirements, and with ASME guidelines effecting non-standard approach conditions. These elements serve as the primary signals for the airflow systems; it shall be the responsibility of the contractor to verify correct installation, to assure that accurate primary signals are obtained.
2. An identification label shall be place on each duct static pressure sensing element showing airflow direction and listing the Model No.; System Served, Size and Identifying Tag No.

Manufacturer

1. Pressure sensing elements shall be Paragon Controls Inc. Model PE-5000 or equal as approved by the Engineer.
2. Naming of a manufacturer does not automatically constitute acceptance of this standard product nor waive the responsibility of the manufacturer to comply totally with all requirements of the proceeding specification.