



FT & FIT-1005 SERIES AIR VOLUME/ VELOCITY TRANSDUCERS

DESCRIPTION

FT & FIT-1005 Series transducers include **Models FT-1005, FIT-1005-M, and FIT-1005-MCP**. FT & FIT-1005 Series are differential pressure transducers with a square root extractor, scaling multiplier, and output filter complete in a single package.

The differential pressure transducer sensor operates on the capacitance principal and is capable of sensing ultra low differential (velocity) pressures. In the capacitance cell, a very lightweight, responsive diaphragm deflects a small amount when pressure is applied. This deflection results in a change in capacitance, which is then detected and processed electronically into an output signal linear to the velocity pressure. The electronic signal is then sent to the square root extractor/multiplier, which converts the velocity pressure signal into an analog output linear to velocity (fpm) or volume (cfm).

The FIT Series includes local indication of the measured process air velocity and/or volume on an independent front panel mounted magnehelic pressure gauge scaled in both cfm and fpm (indicated by a "M" in the model number). The independent magnehelic gauge readout allows for quick and immediate verification that the electronic transducer is operating effectively.

An optional constant volume purge feature prevents contaminants from migrating to the differential pressure sensor (indicated by a "CP" in the model number).

Each FT & FIT-1005 Series transducer is selected and factory calibrated to meet the design requirement of the flow measuring element being served.

Features

- Field selectable 4-20 mA or 0-10 VDC output, (optional 0-5 VDC output)
- $\pm 0.5\%$ F.S. accuracy
 $\pm 0.25\%$ F.S. accuracy (optional)
- Square root extractor/multiplier
- Local indication of flow on an independent magnehelic pressure gauge
- Continuous constant volume purge
- Full scale ranges as low as 1,266 fpm
- Can be operated continuously in temperature ranges of 32 to 160 °F
- Can be stored in temperature ranges of -40 to 180 °F
- Standard zero shift of only $\pm 0.025\%$ F.S./°F
Zero shift of only $\pm 0.015\%$ F.S./°F (optional)
- Standard span shift of only $\pm 0.025\%$ F.S./°F
Span shift of only $\pm 0.015\%$ F.S./°F (optional)
- 25 psi maximum static line pressure
- Differential overpressure of 5 psi proof and 25 psi burst
- Vibration less than 0.05% F.S. temporary effect with 5g's, 0-60 Hz
- Non-corrosive dry gas pressure media
- Pneumatic ¼" compression process input connection



FT & FIT-1005 Series Technical Specifications

1. AVAILABLE FULL SCALE RANGES

No.	Velocity (fpm)
1	1,266
2	2,003
3	2,832
4	3,468
5	4,005
6	5,664
7	6,937
8	8,955
9	12,665

2. PROCESS INPUT CONNECTION

Pneumatic 1/4" compression suitable for either hard or soft wall signal tubing

3. ENCLOSURE

FT-1005

NEMA 12, steel

FIT-1005-M

NEMA 1, aluminum

FIT-1001-MCP

NEMA 12, steel

4. PRESSURE MEDIA

Non-corrosive dry gases

5. OPERABLE LINE PRESSURE

FT-1005 & FIT-1005-M

25 psi maximum static line pressure

6. MAIN AIR REQUIREMENTS

FIT-1005-MCP

20 PSI Instrument Air @ 100 SCIM max

7. DIFFERENTIAL OVERPRESSURE

5 psi proof and 25 psi burst pressure

8. VIBRATION

<0.05% F.S. temporary effect with 5g's,
0-60 Hz

9. FULL SCALE ACCURACY DATA AT 70°F

	<u>Standard</u>	<u>Optional</u>
Combined accuracy	±0.50%	±0.25%
Terminal point nonlinearity	±0.40%	±0.20%
Hysteresis	±0.02%	±0.02%
Non-repeatability	±0.05%	±0.03%

10. ENVIRONMENTAL ATTRIBUTES

Storage	-40 ~ 180°F	-40 ~ 82°C
Operating	32 ~ 160°F	0 ~ 70°C
Compensation Range	40 ~ 125°F	4 ~ 52°C
Zero shift **	±0.025%FS/°F	±0.025%FS/½°C
Span shift **	±0.025%FS/°F	±0.025%FS/½°C
** Opt 0.25%	±0.015%FS/°F	±0.015%FS/½°C
Accuracy		

11. ELECTRICAL INFORMATION

Output	Field selectable 4 ~ 20mA or 0 ~ 10VDC, (optional 0 ~ 5VDC)
Supply Power	18 ~ 28 VDC/AC; 50 ~ 60Hz; 150mA
Connections	Removable plug with screw terminals
External Load	500 Ω max

12. APPROXIMATE WEIGHT

FT-1005

3.0 LBS

FIT-1005-M

3.5 LBS

FIT-1005-MCP

16 LBS



FT & FIT-1005 Series Ordering Information

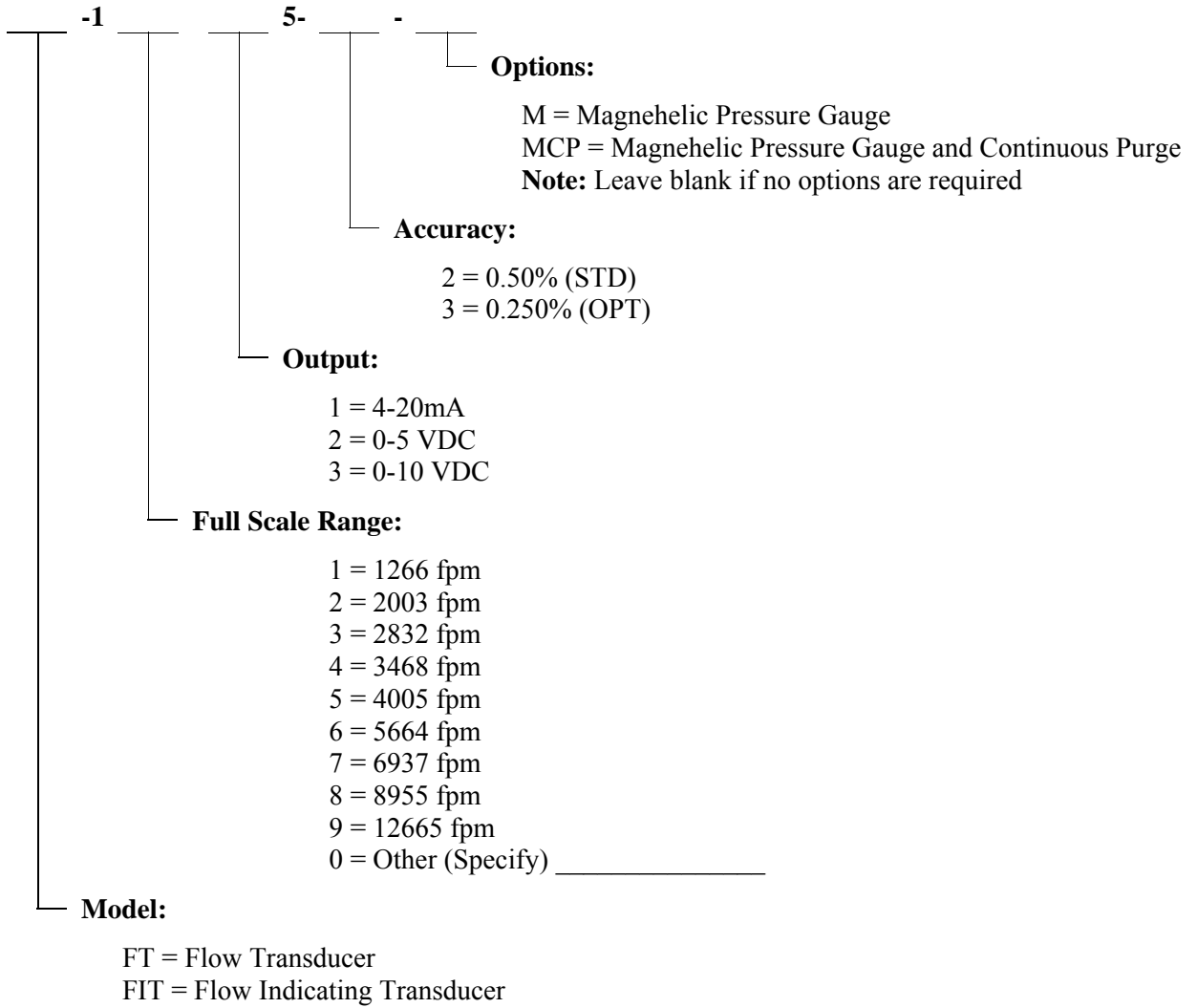

FT-1005 Dimensions

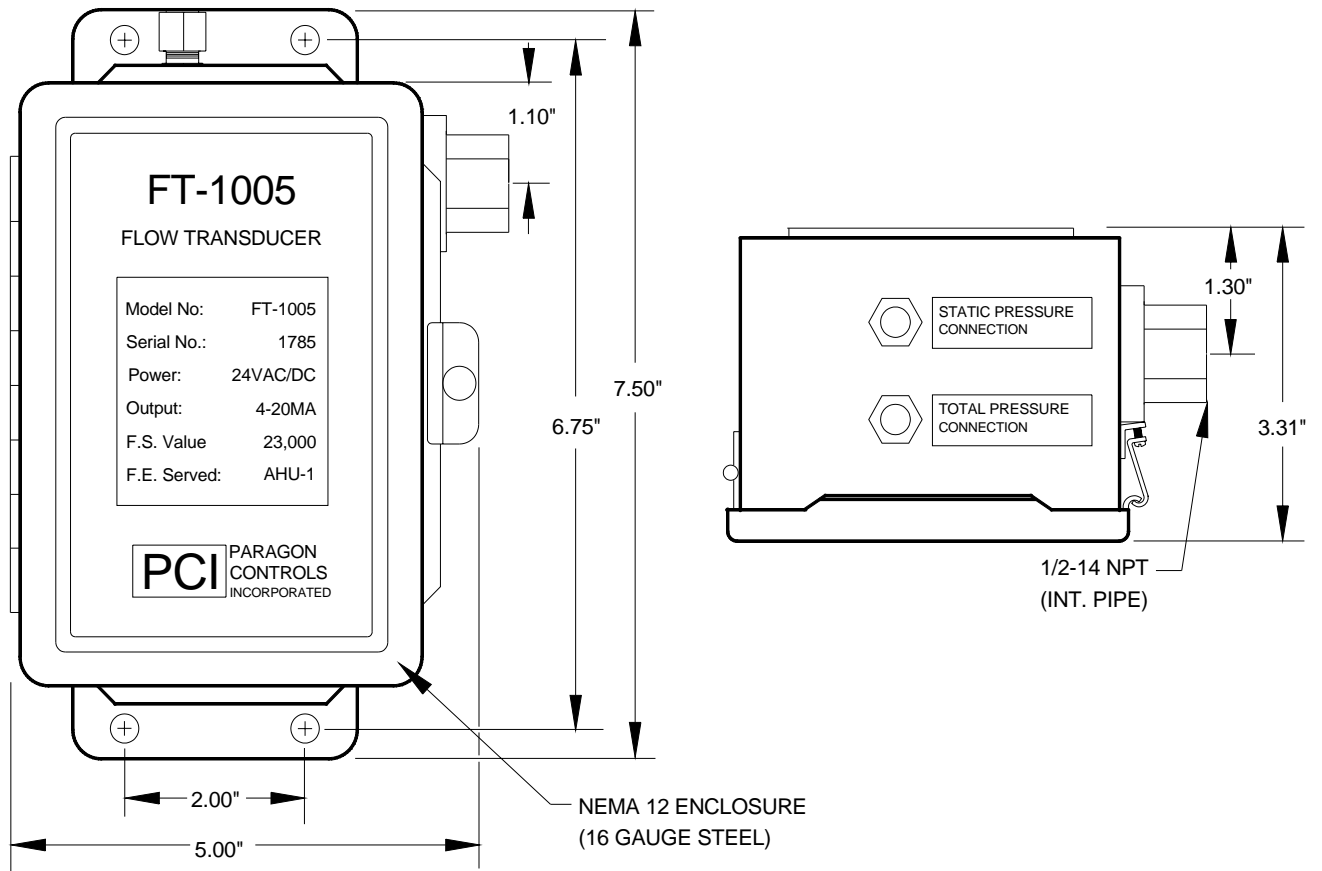

FT-1005 Field Connections

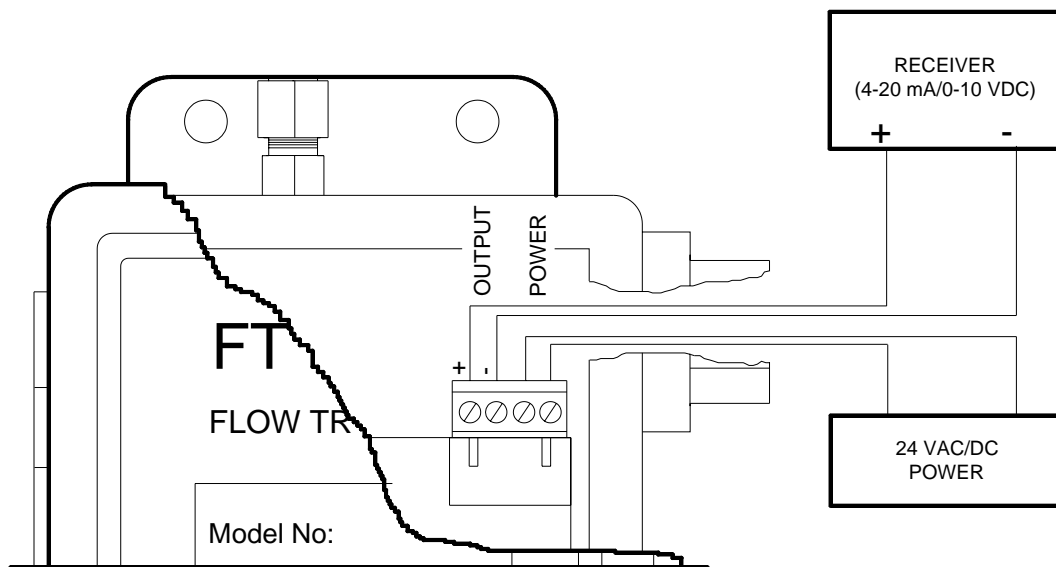

FIT-1005-M Dimensions

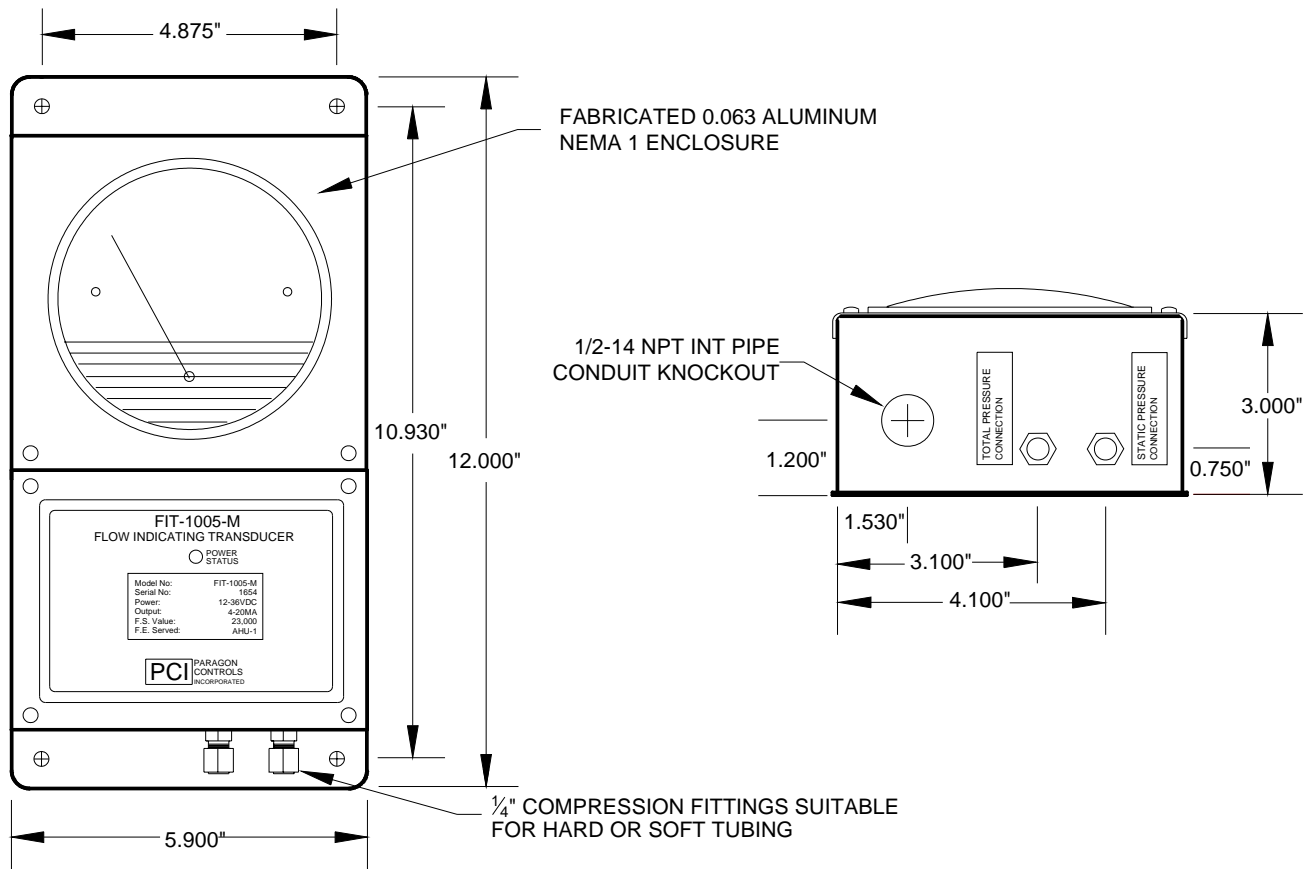

FIT-1005-M Field Connections

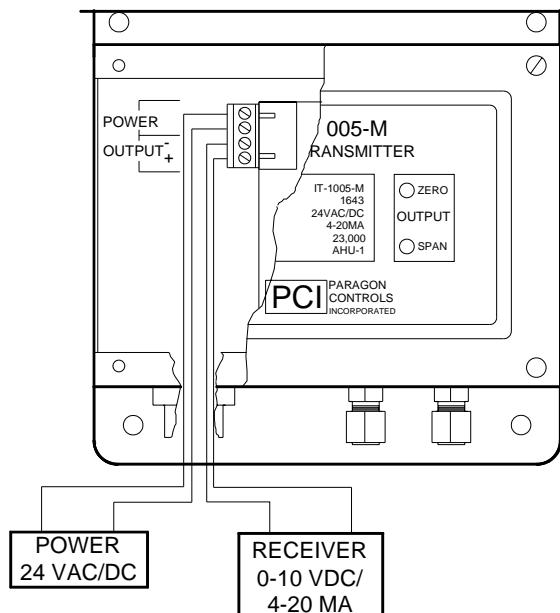

FIT-1005-MCP Dimensions

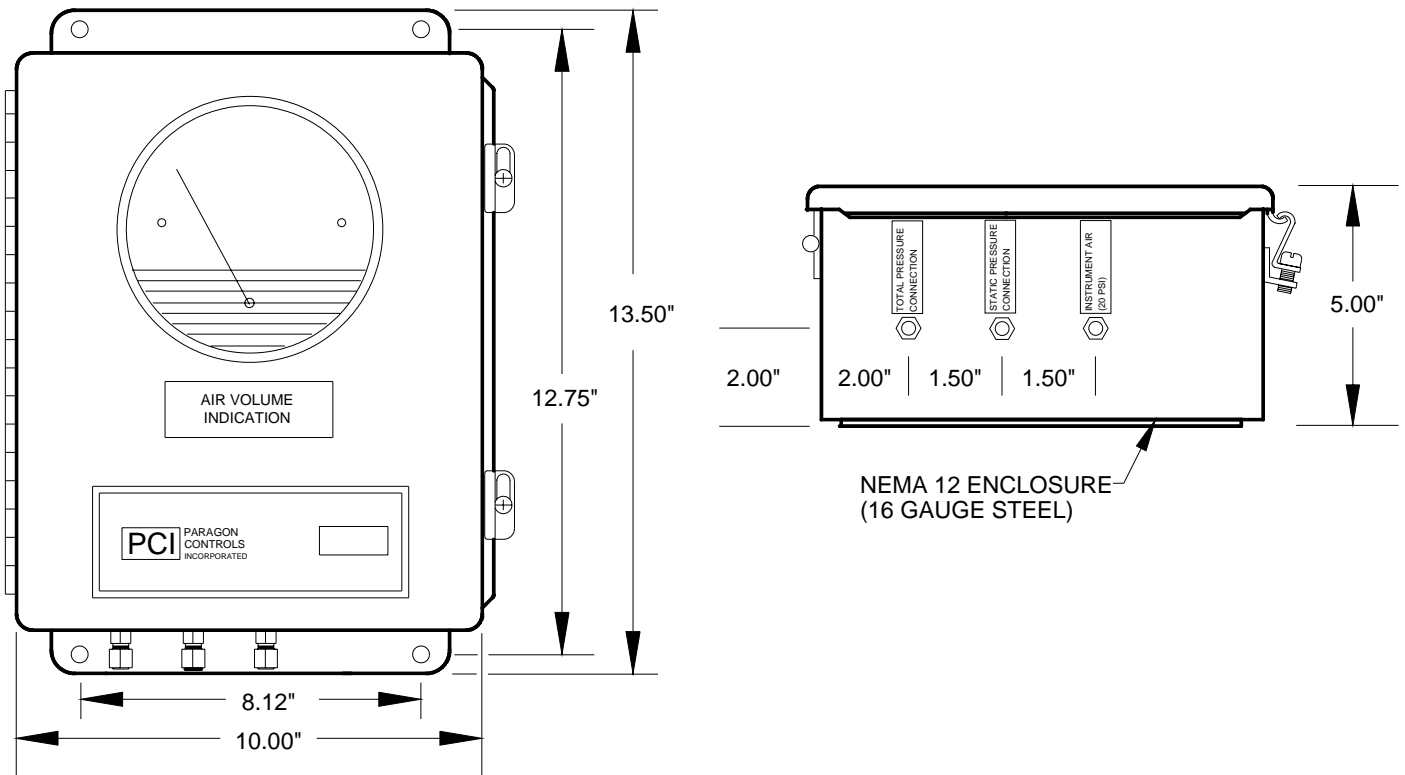

FIT-1005-MCP Field Connections

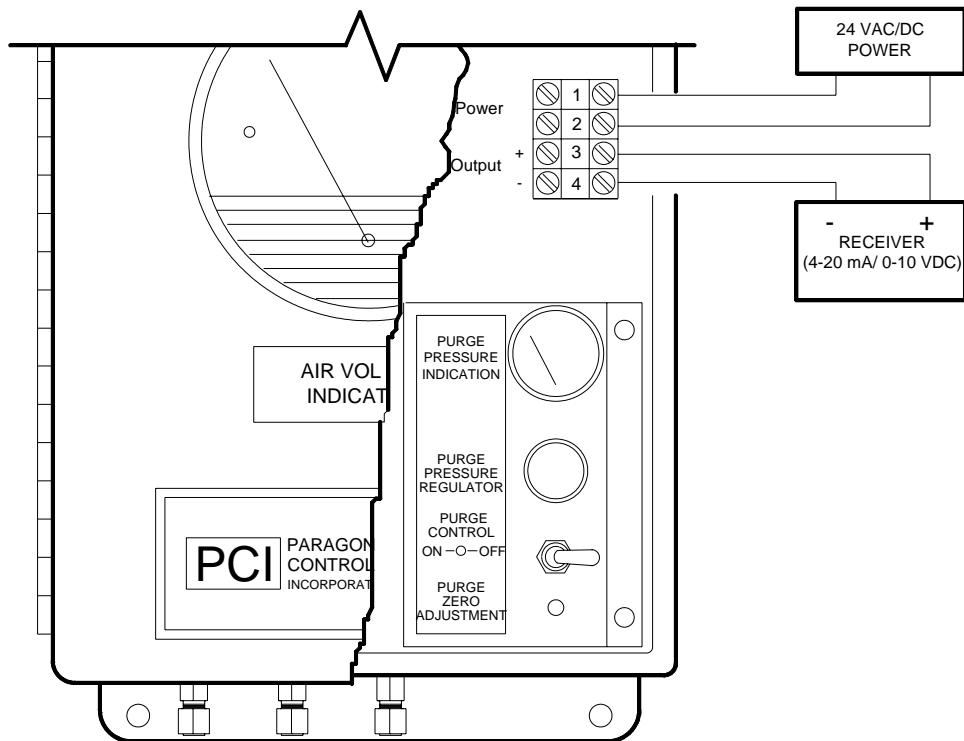

FT & FIT-1005 Series Specification Guide

Electronic Transducers

1. Provide individual airflow transducers selected for the required design airflow rate of the primary element served. Each transducer shall be selected for its respective duty. Supply, Exhaust and/or Return Airflow Transducers shall provide analog output signal linear to air volume that are factory set for a full scale value equal to 110% of the maximum design capacity of the airflow measuring element served for variable air volume applications, or 200% of the design operating value for constant volume applications.
2. The transducer(s) shall be solid state electronic type, with infinite output resolution, capable of performing dedicated air volume measurement and indication functions. Microprocessor based transducers with time sharing of multiple square root extractors and/or controllers are not acceptable.
3. Each transducer's output shall not be affected by direction of mounting (attitude) or external vibrations, and shall be furnished with a factory calibrated span that matches the application.
4. Transducer performance shall be equal to or better than the following:
Accuracy: 0.5% F.S. (Terminal Point) / 0.35% F.S. (BFSL)
Temperature Effects: <0.03% F.S./°F
Over-pressure: 5 PSIG Proof / 10 PSIG Burst
Response: <0.25 seconds for full span input
Noise Filtration: Low Pass Filter, factory set @ 3.2Hz

Additional Specifications for Electronic Transducer Options

- **Magnehelic Pressure Gauge:** Airflow transducers shall be provided with an integral dual scale indicating meter operating independent of all other control devices. The top scale shall indicate the measured air volume in units of cubic feet per minute (cfm), and the bottom scale shall indicate the air velocity in units of feet per minute (fpm). The meter shall be a differential pressure type that is diaphragm actuated, and is to be flush mounted on the enclosure door. The meter shall be calibrated to an accuracy of ±2% of span (±3% of span for 0.5 inch water column magnehelic gauge or ±4% of span for 0.25 inch water column magnehelic gauge).
- **Continuous Purge:** Each transducer shall be provided with a constant volume purge feature that prevents contaminants from migrating to the differential pressure sensor.

Labeling

1. An identification label shall be placed on each transducer listing the model number, airflow measuring elements served, full scale value, and identifying tag number.

Manufacturer

1. Electronic transducers shall be Paragon Controls Inc. Model [FT-1005] [FIT-1005-M] [FIT-1005-MCP] or equal as approved by the Design Engineer.
2. Naming of a manufacturer does not automatically constitute acceptance of this standard product nor waive the responsibility of the manufacturer to comply totally with all requirements of the proceeding specification.

