



FT & FIT-1001 SERIES AIR VOLUME/ VELOCITY TRANSDUCERS

DESCRIPTION

FT & FIT-1001 Series transducers include **Models FT-1001, FT-1001-ZV, FIT-1001-D, FIT-1001-DZV, FIT-1001-M, and FIT-1001-MZV**. FT & FIT-1001 Series are differential pressure transducers with a square root extractor, scaling multiplier, and output filter complete in a single package.

The differential pressure transducer sensor operates on the capacitance principal and is capable of sensing ultra low differential (velocity) pressures. In the capacitance cell, a very lightweight, responsive diaphragm deflects a small amount when pressure is applied. This deflection results in a change in capacitance, which is then detected and processed electronically into an output signal linear to the velocity pressure. The electronic signal is then sent to the square root extractor/multiplier, which converts the velocity pressure signal into an analog output linear to velocity (fpm) or volume (cfm).

The FIT Series includes local indication of the measured process air velocity and/or volume on either a 0.5 inch high 3-1/2 digit LCD display meter scaled in cfm (indicated by a "D" in the model number) or an independent front panel mounted magnehelic pressure gauge scaled in both cfm and fpm (indicated by a "M" in the model number). The independent magnehelic gauge readout allows for quick and immediate verification that the electronic transducer is operating effectively.

An optional built-in three-way manual zeroing valve for ease of zero verification and calibration can also be furnished (indicated by a "ZV" in the model number).

Each FT & FIT-1001 Series transducer is selected and factory calibrated to meet the design requirement of the flow measuring element being served.

Features

- Two wire 4-20 mA output
- $\pm 1\%$ F.S. accuracy
 $\pm 0.5\%$ F.S. accuracy (optional)
- Square root extractor/multiplier
- Local indication of flow on a LCD display meter or independent indication of flow on a magnehelic pressure gauge
- Manual three-way zeroing valve
- Full scale ranges as low as 1,266 fpm
- Can be operated continuously in temperature ranges of 32 to 160 °F
- Can be stored in temperature ranges of -40 to 180 °F
- Zero shift of only $\pm 0.025\%$ F.S. per °F
- Span shift of only $\pm 0.025\%$ F.S per 0F
- 25 psi maximum static line pressure
- Differential overpressure of 5 psi proof and 25 psi burst
- Vibration less than 0.05% F.S. temporary effect with 5g's, 0-60 Hz
- Non-corrosive dry gas pressure media
- Pneumatic 1/4" barb process input connection



FT & FIT-1001 Series Technical Specifications

1. AVAILABLE FULL SCALE RANGES

No.	Velocity (fpm)
1	1,266
2	2,003
3	2,832
4	3,468
5	4,005
6	5,664
7	6,937
8	8,955
9	12,665

2. PROCESS INPUT CONNECTION

FT-1001, FT-1001-ZV, FIT-1001-D, & FIT-1001-DZV

Pneumatic 1/4" barb

FIT-1001-M & FIT-1001-MZV

Pneumatic 1/4" compression suitable for either hard or soft wall signal tubing

3. ENCLOSURE

FT-1001

FR110 polycarbonate

FT-1001-ZV, FIT-1001-D, & FIT-1001-DZV

Flame retardant ABS plastic

FIT-1001-M & FIT-1001-MZV

NEMA 1, Aluminum

4. PRESSURE MEDIA

Non-corrosive dry gases

5. OPERABLE LINE PRESSURE

25 psi maximum static line pressure

6. DIFFERENTIAL OVERPRESSURE

5 psi proof and 25 psi burst pressure

7. VIBRATION

<0.05% F.S. temporary effect with 5g's,
0-60 Hz

8. FULL SCALE ACCURACY DATA AT 70°F

	Standard	Optional
Combined accuracy	±1.00%	±0.50%
Terminal point nonlinearity	±0.80%	±0.40%
Hysteresis	±0.05%	±0.02%
Non-repeatability	±0.10%	±0.05%

9. ENVIRONMENTAL ATTRIBUTES

Storage	-40 ~ 180°F	-40 ~ 82°C
Operating	32 ~ 160°F (10-95% R.H. non-condensing)	0 ~ 70°C
Compensation Range	40 ~ 125°F	4 ~ 52°C
Zero shift	±0.025%FS/°F	±0.025%FS/½°C
Span shift	±0.025%FS/°F	±0.025%FS/½°C

10. ELECTRICAL INFORMATION

FT-1001, FT-1001-ZV, FIT-1001-M & FIT-1001-MZV

Output	4 ~ 20mA (2 Wire)
Supply Power	12 ~ 36 VDC $V_{min} = 12 + (0.022 \times R_{LOAD})$
Connections	Removable Plug with Screw Terminals
External Load	1090 Ω max. @ 36 VDC

FIT-1001-D & FIT-1001-DZV

Output	4 ~ 20mA (2 Wire)
Supply Power	18 ~ 36 VDC $V_{min} = 12 + [0.022 \times (R_{LOAD} + 300)]$
Connections	Removable Plug with Screw Terminals
External Load	790 Ω max. @ 36 VDC

11. APPROXIMATE WEIGHT

FT-1001

6 OZ

FT-1001-ZV, FIT-1001-D & FIT-1001-DZV

1.2 LB

FIT-1001-M & FIT-1001-MZV

3 LB

FT & FIT-1001 Series Ordering Information

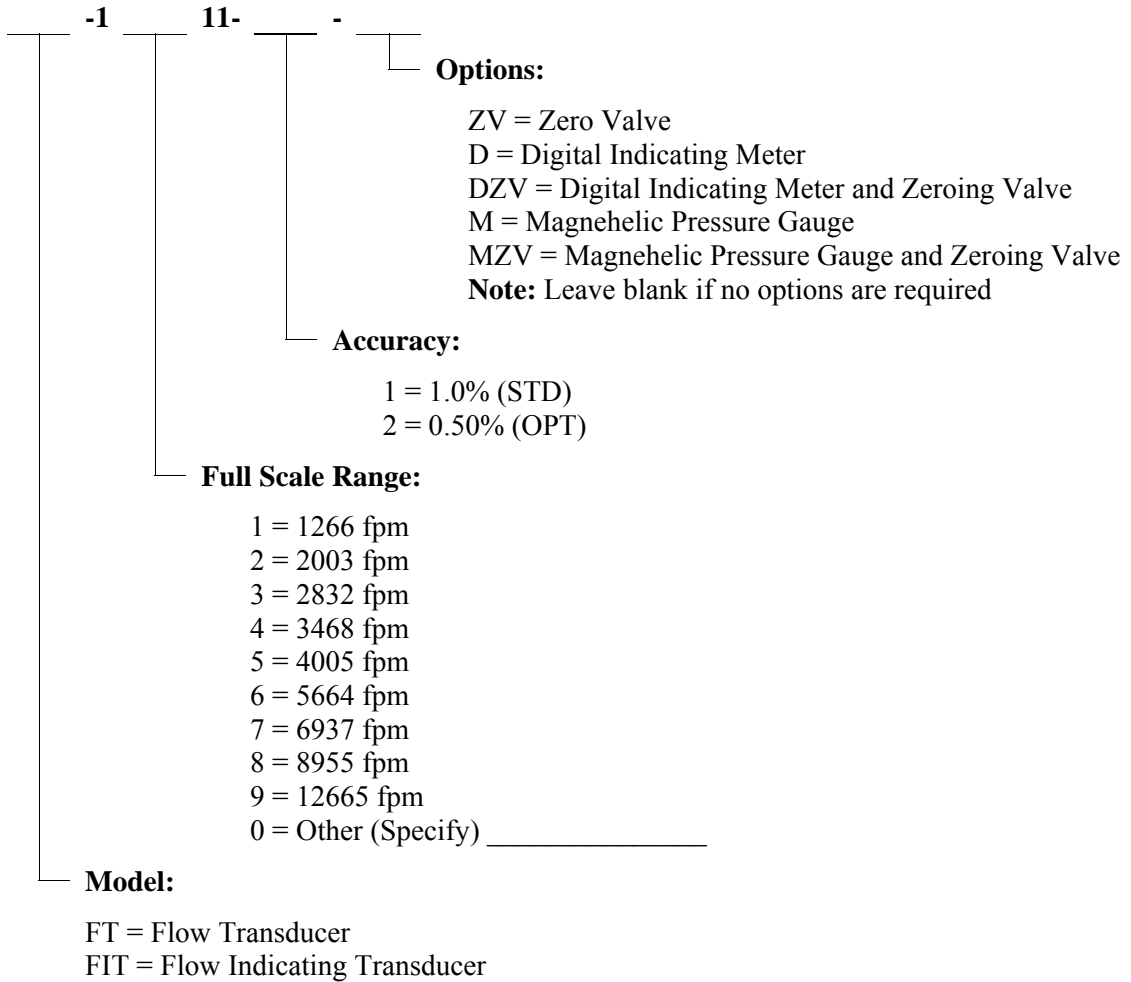

FT-1001 Dimensions

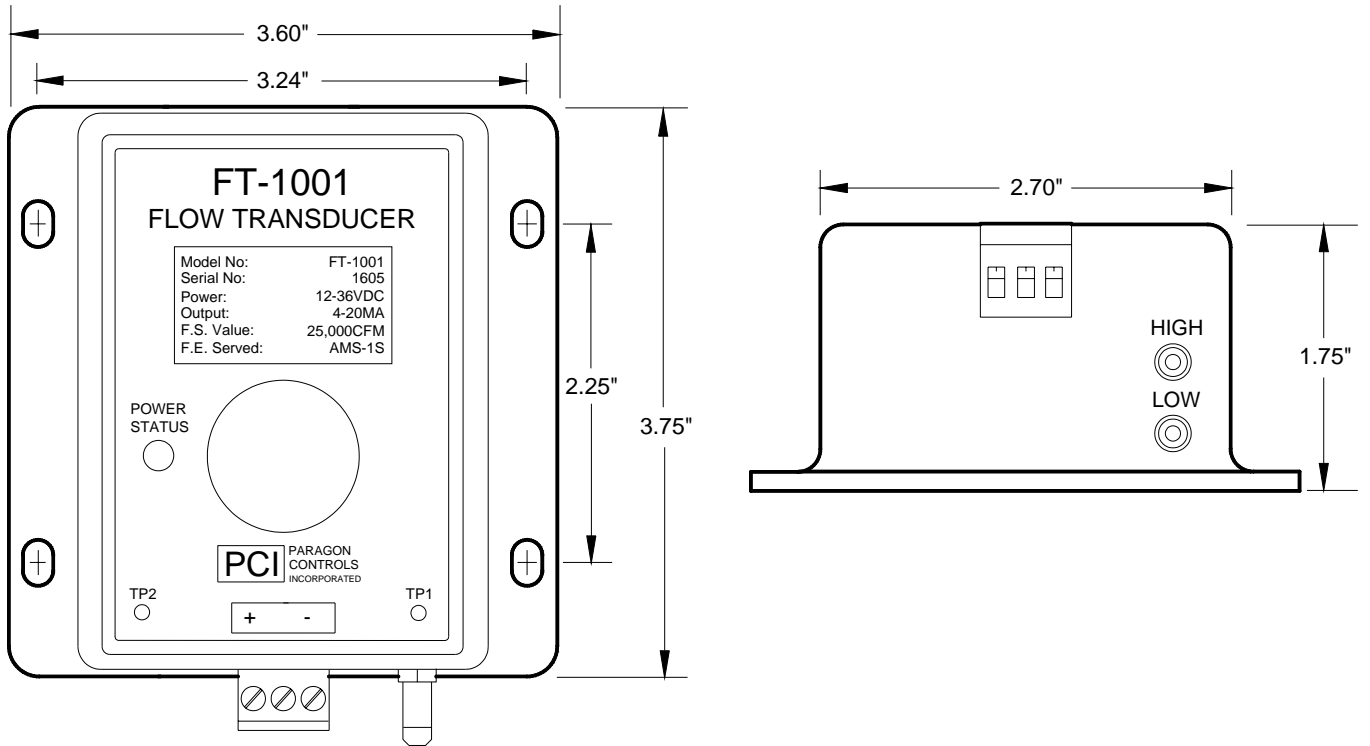

FT-1001 Field Connections and Load Limitations

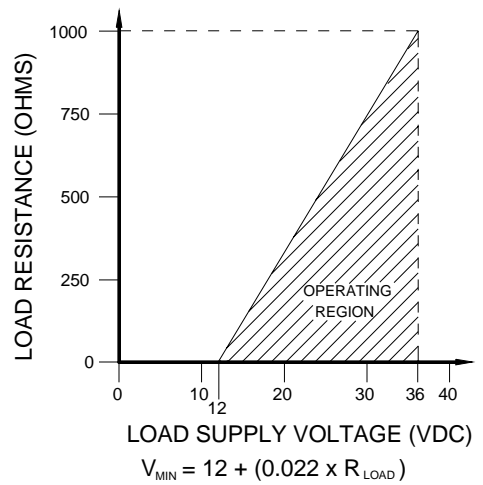
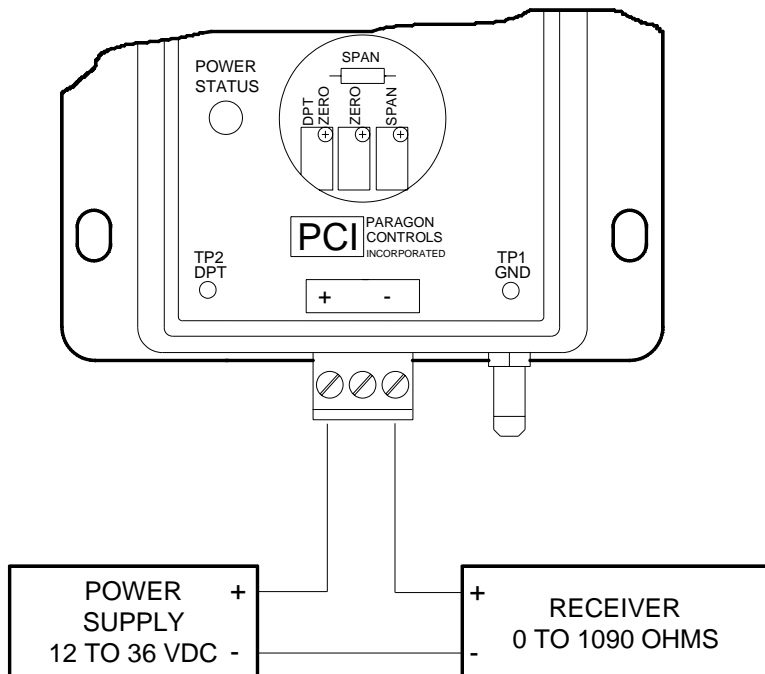

FT-1001-ZV Dimensions

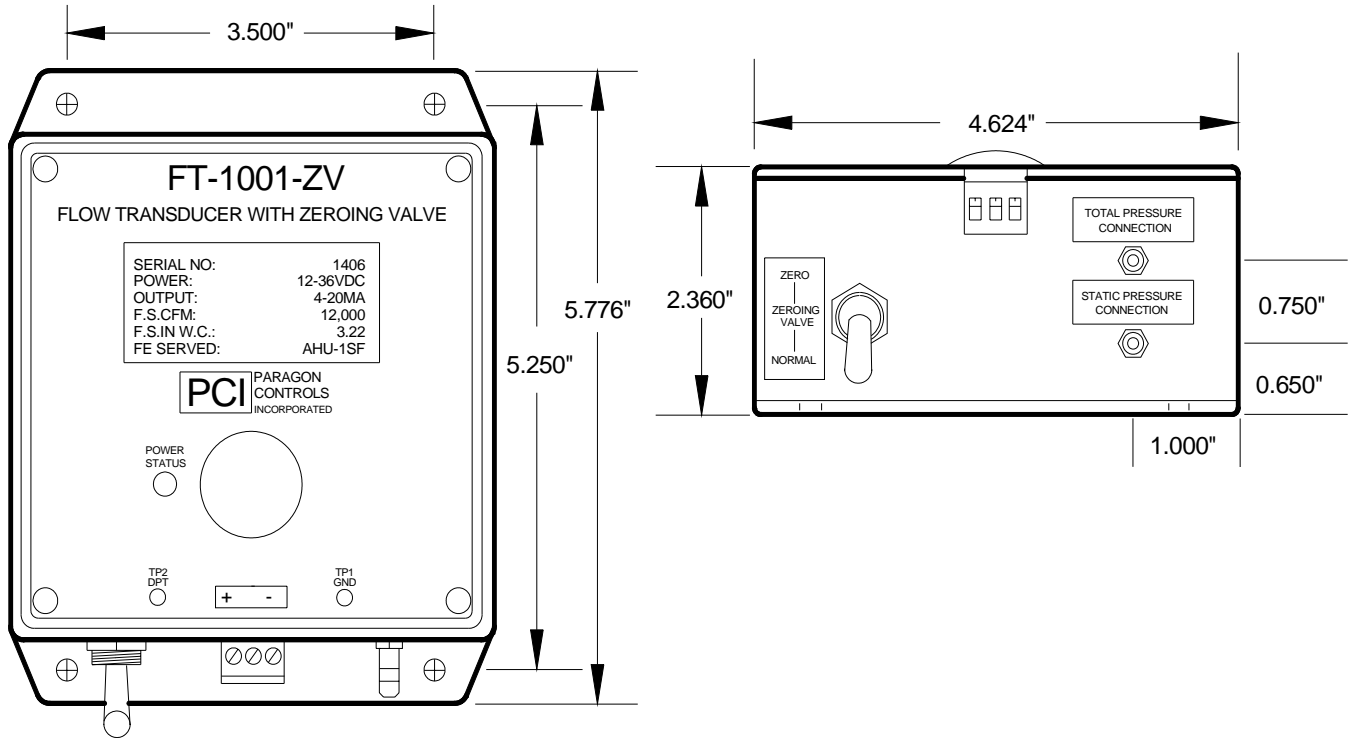

FT-1001-ZV Field Connections and Load Limitations

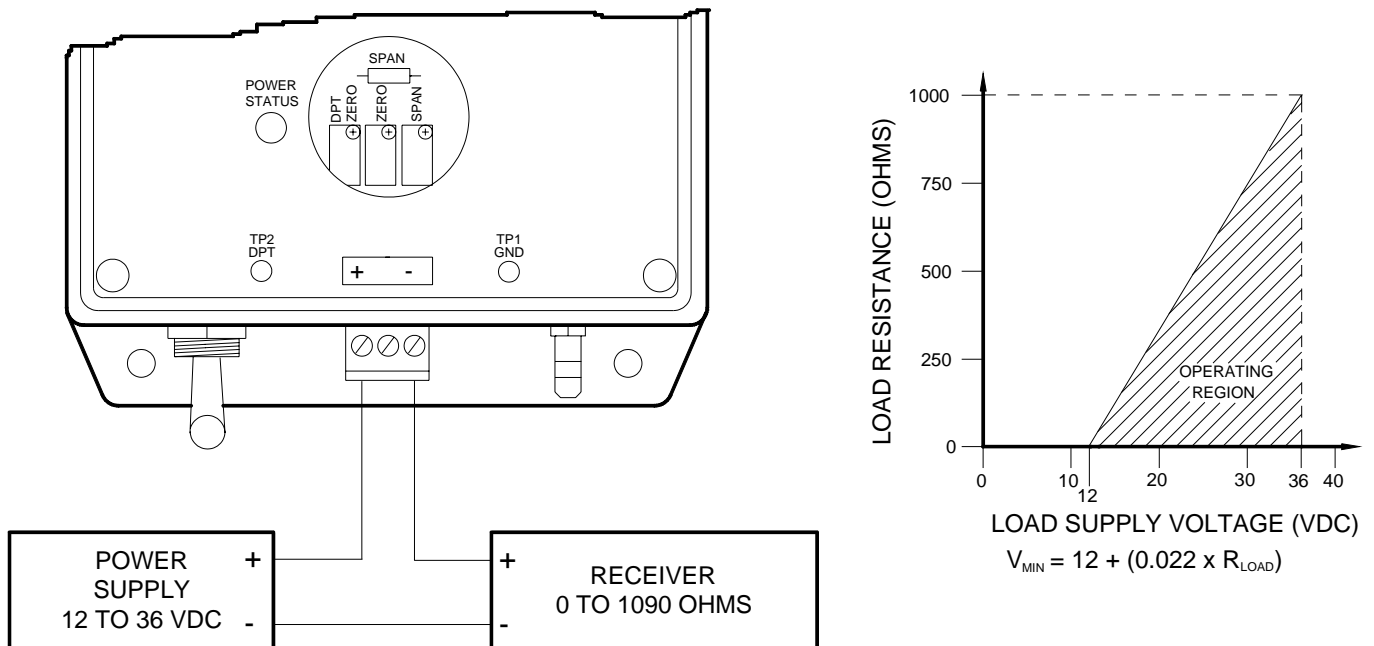

FIT-1001-D & FIT-1001-DZV Dimensions

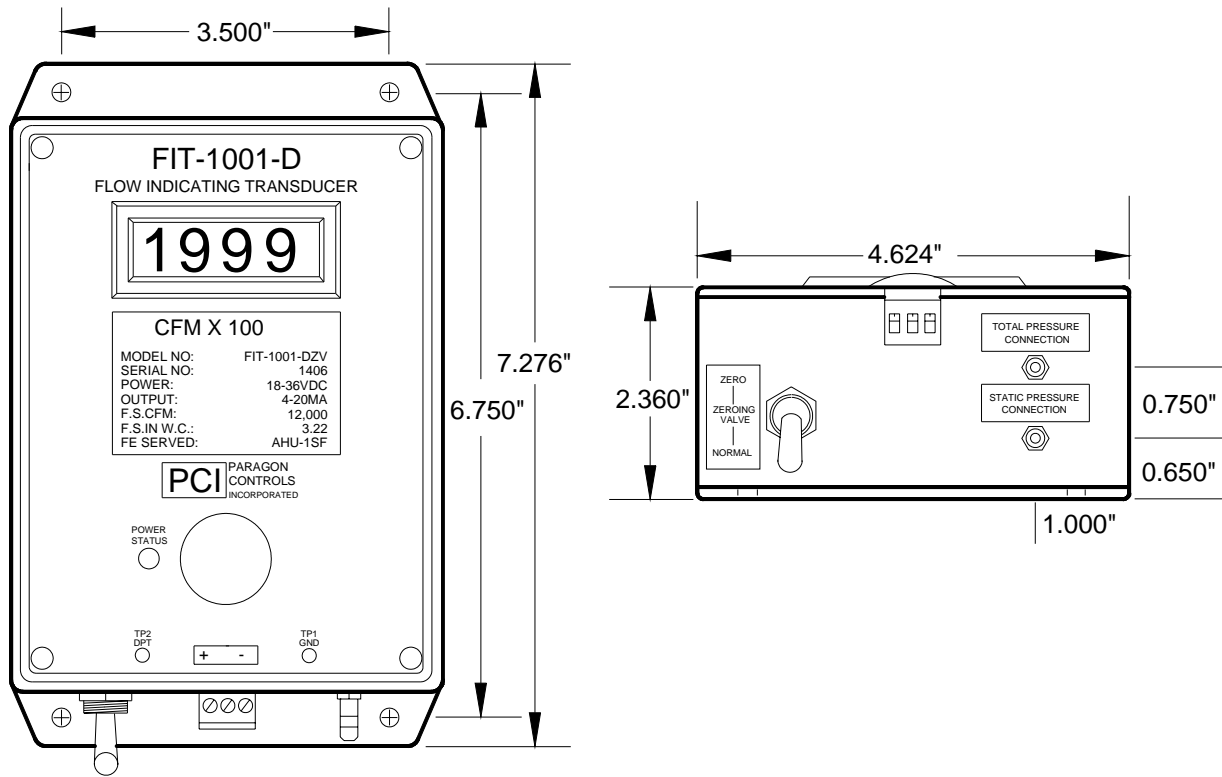

FIT-1001-D & FIT-1001-DZV Field Connections and Load Limitations

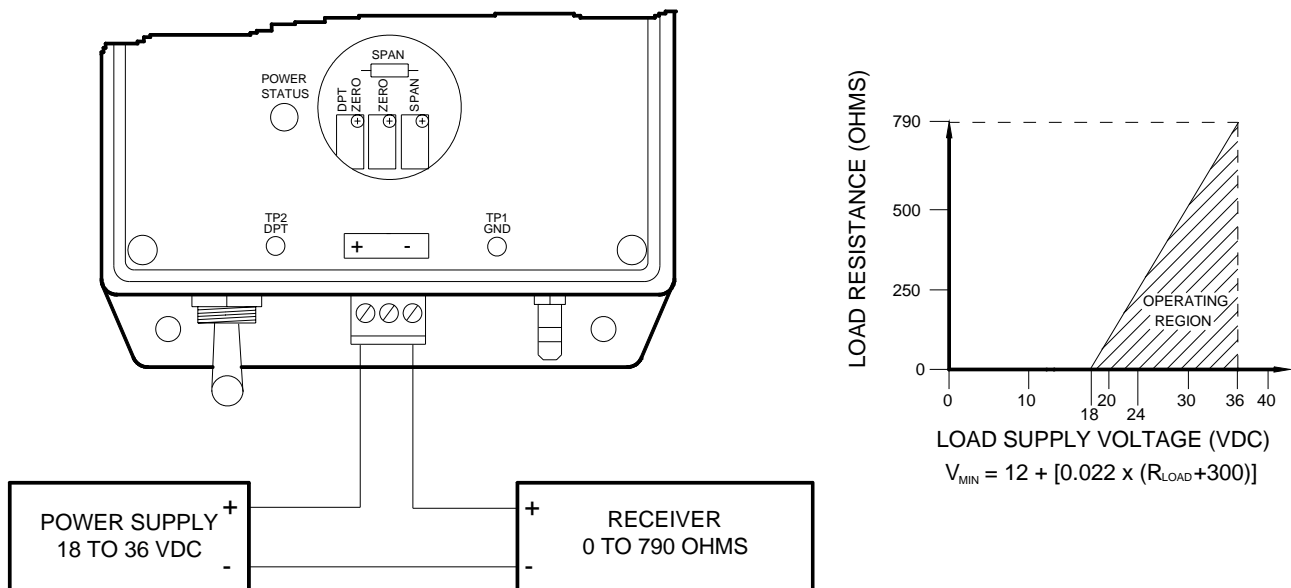

FIT-1001-M & FIT-1001-MZV Dimensions

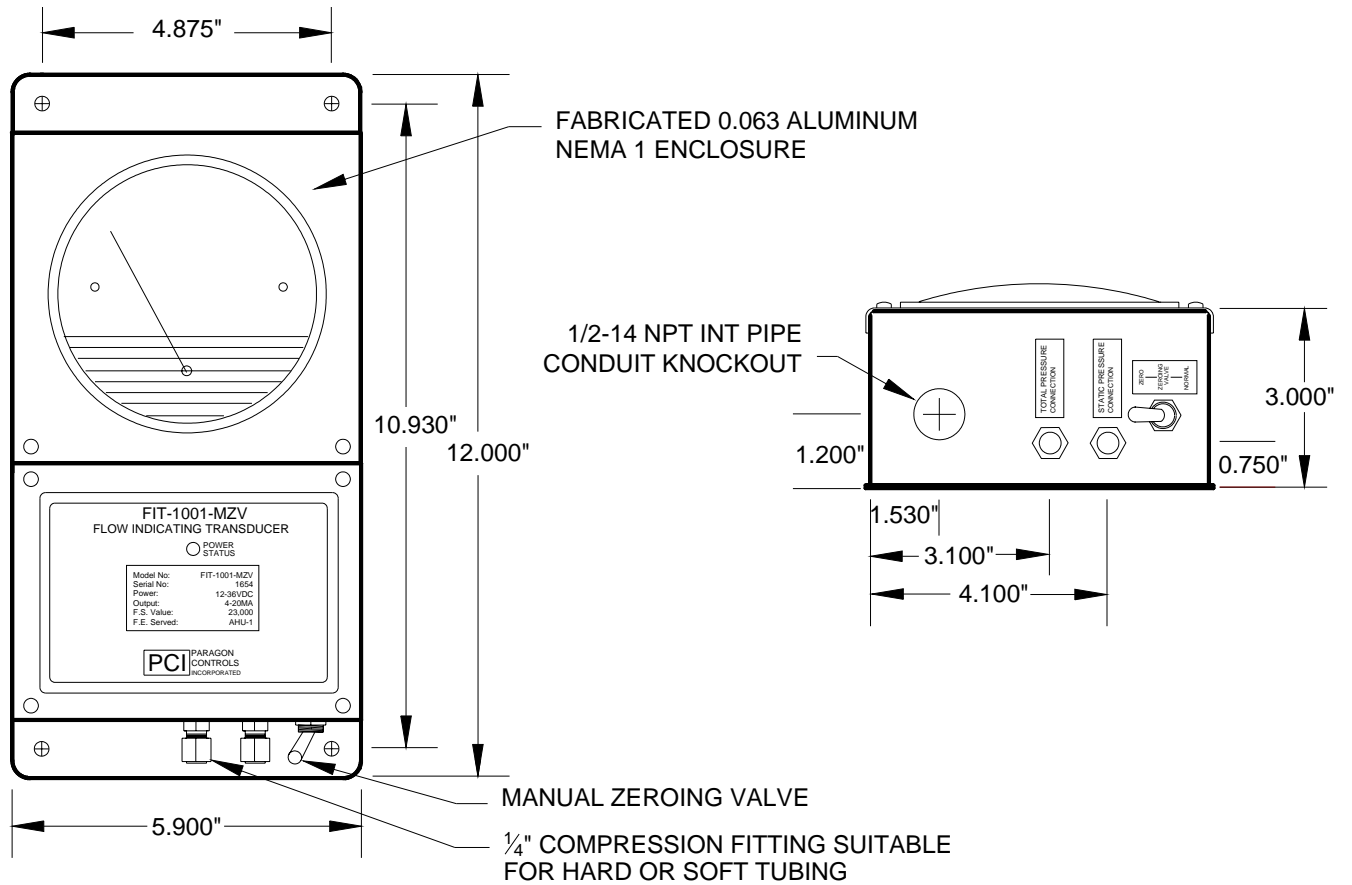

FIT-1001-M & FIT-1001-MZV Field Connections and Load Limitations

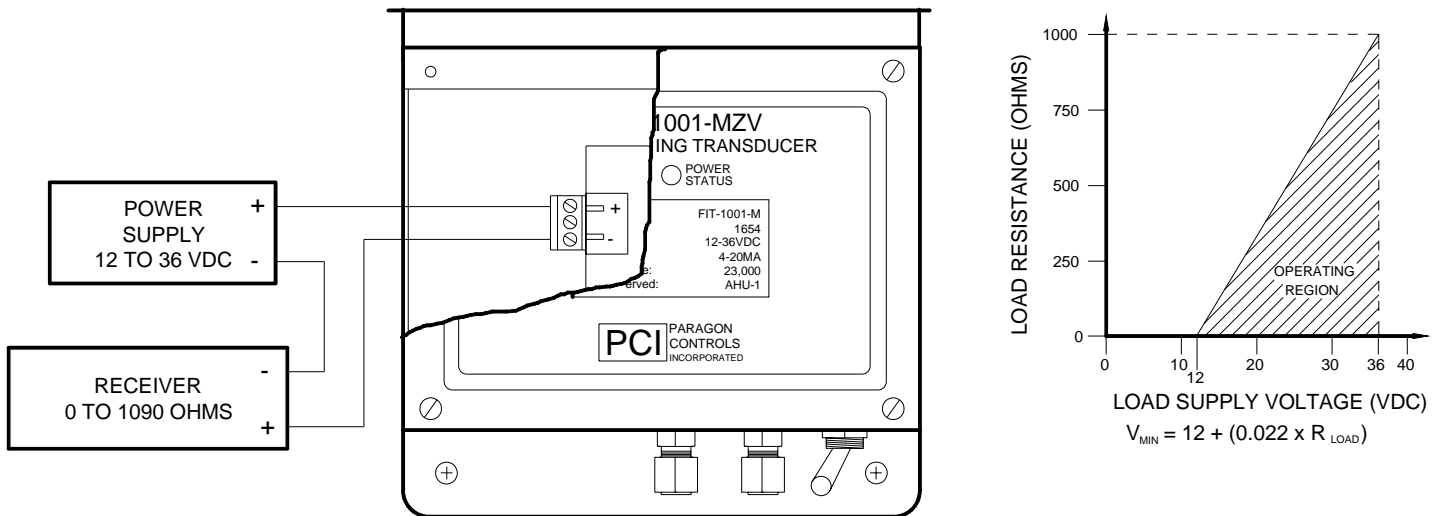

FT & FIT-1001 Series Specification Guide

Electronic Transducers

1. Provide individual airflow transducers selected for the required design airflow rate of the primary element served. Each transducer shall be selected for its respective duty. Supply, Exhaust and/or Return Airflow Transducers shall provide analog output signal linear to air volume that are factory set for a full scale value equal to 110% of the maximum design capacity of the airflow measuring element served for variable air volume applications, or 200% of the design operating value for constant volume applications.
2. The transducer(s) shall be solid state electronic type, with infinite output resolution, capable of performing dedicated air volume measurement and indication functions. Microprocessor based transducers with time sharing of multiple square root extractors and/or controllers are not acceptable.
3. Each transducer's output shall not be affected by direction of mounting (attitude) or external vibrations, and shall be furnished with a factory calibrated span that matches the application.
4. Transducer performance shall be equal to or better than the following:
Accuracy: 0.5% F.S. (Terminal Point) / 0.35% F.S. (BFSL)
Temperature Effects: <0.03% F.S./°F
Over-pressure: 5 PSIG Proof / 10 PSIG Burst
Response: <0.25 seconds for full span input
Noise Filtration: Low Pass Filter, factory set @ 3.2Hz

Additional Specifications for Electronic Transducer Options

- **Zeroing Valve:** Each transducer shall be provided with an integral manual zeroing valve to allow for field calibration of the zero reference value without the need for shutting the operating system down.
- **Digital Indication:** Airflow transducers shall be provided with an integral digital indicating meter that shall indicate the measured air volume in units of cubic feet per minute (cfm).
- **Magnehelic Pressure Gauge:** Airflow transducers shall be provided with an integral dual scale indicating meter operating independent of all other control devices. The top scale shall indicate the measured air volume in units of cubic feet per minute (cfm), and the bottom scale shall indicate the air velocity in units of feet per minute (fpm). The meter shall be calibrated to an accuracy of $\pm 2\%$ of span ($\pm 3\%$ of span for 0.5 inch water column magnehelic gauge or $\pm 4\%$ of span for 0.25 inch water column magnehelic gauge).

Labeling

1. An identification label shall be placed on each transducer listing the model number, airflow measuring elements served, full scale value, and identifying tag number.

Manufacturer

1. Electronic transducers shall be Paragon Controls Inc. Model [FT-1001] [FT-1001-ZV] [FIT-1001-D] [FIT-1001-DZV] [FIT-1001-M] [FIT-1001-MZV] or equal as approved by the Design Engineer.
2. Naming of a manufacturer does not automatically constitute acceptance of this standard product nor waive the responsibility of the manufacturer to comply totally with all requirements of the proceeding specification.