

APPLICATIONS

Airflow Volume Control

Constant volume (CV): Constant volume controllers (C) are typically used for snorkels, biosafety cabinets, CV fume hoods, ventilated cabinets and outside air regulation.

Two-position: Pneumatic controllers (P) are typically used for canopy hoods and two-position fume hoods. Base upgradable controllers (B) can be substituted when flow feedback is required or upgradability to VAV is desired.

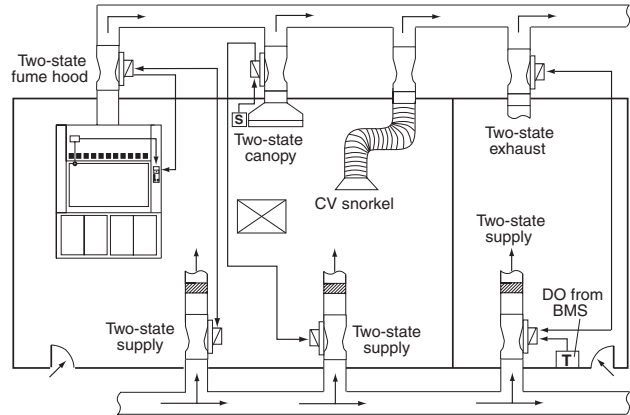

SPECIFICATIONS

Construction

- 16 ga. spun aluminum valve body with continuous welded seam
- Valve bodies available as uncoated aluminum or with corrosion-resistant baked phenolic coatings
- Composite Teflon® shaft bearings
- Spring grade stainless steel spring and polyester or PPS slider assembly
- Supply valves insulated with 3/8" (9.5 mm) flexible closed-cell polyethylene. Flame/smoke rating 25/50. Density is 2.0 lb/ft³ (32.0 kg/m³)

Operating Range

- 32-122 °F (0-50 °C) ambient
- 10-90% non-condensing RH

Sound

Designed for low sound power levels to meet or exceed ASHRAE noise guidelines.

Performance

- Pressure independent over a 0.6"-3.0" wc (150-750 Pa) drop across valve
- Volume control accurate to ±5% of airflow command signal

- No additional straight duct runs needed before or after valve
- Available in flows from 35-6000 CFM (60-10,000 m³/hr)
- Response time to change in duct static pressure: <1 second

Pneumatic Actuation

- Only applicable to PEV, PSV and BEV/BSV
- 20 psi (-0/+2 psi) with a 20 micron filter main air required
- Compressor sizing: Accel II Valves are not continuous air-consuming devices. For compressor sizing, use:
 - single and dual valves: 10 scim
 - triple and quad valves: 20 scim

Flow Feedback

- Power:
- ±15 Vdc, ±5%
 - single and dual valves: 0.012 amps
 - triple and quad valves: 0.024 amps
 - 0-10 Vdc flow feedback signal



Teflon is a registered trademark of DuPont Co.

FEATURES

FEATURE/OPTION	Constant Volume (CVV)	Two-position (PEV/PSV)	Upgradable (BEV/BSV)
Control type	C Constant Volume	P Pneumatic	B Base Upgradable
Actuator type	—	Pneumatic	Pneumatic or CV
Flow feedback signal	—	—	Option
Failsafe	Fixed	NO/NC	NO/NC
Factory-insulated valve body (supply)	Option	✓	✓
Field-adjustable flow	✓	✓	✓
Flow alarm via feedback circuit	—	—	—
Flow alarm via pressure switch	Option	Option	Option
Low noise diffuser construction†	✓	✓	✓

All valves include pressure independent controller, factory-calibrated position controller.

†Accel II valves are designed to reduce sound over all frequencies, but significantly target the lower bands (125-500 Hz) to help eliminate the need for silencers.

ORDERING GUIDE

BSV A 1 1 0 M - A B F H C - P - - - - -

VALVE FAMILY

(see note 1)
CVV = Constant volume valve
PEV = Pneumatic exhaust valve
PSV = Pneumatic supply valve
BEV = Base electronic exhaust valve
BSV = Base electronic supply valve

VALVE CONSTRUCTION

A = Body and cone—uncoated aluminum;
 Shaft—uncoated 316 stainless steel
B = Body and cone with baked phenolic coating, Teflon coated stainless steel shaft (for standard fume hood applications)
C = Body, cone, and hardware with baked phenolic coating, PFA coated stainless steel shaft (for highly corrosive fume hood applications)
S = Special coating and/or components

NUMBER OF VALVE BODIES

F = One valve body with welded circular flange (single flanged)
1 = One valve body (single no flange)
2 = Two valve bodies (dual)
3 = Three valve bodies (triple)
4 = Four valve bodies (quad)

VALVE SIZE

08 = 8" valve (7.88"/200 mm actual diameter)
10 = 10" valve (9.88"/251 mm actual diameter)
12 = 12" valve (11.88"/302 mm actual diameter)

FLOW/PRESSURE OPERATING RANGE

Designation	Size	Specified cfm (m ³ /hr) Range				Pressure Drop Across Valve
		Single	Dual	Triple	Quad	
M = medium pressure	08	35-700 (60-1175)	—	—	—	0.6"-3.0" wc (150-750 Pa)
	10	50-1000 (85-1700)	100-2000 (170-3350)	—	—	
	12	90-1500 (150-2500)	180-3000 (300-5000)	270-4500 (450-7500)	360-6000 (600-10,000)	

FAIL-SAFE POSITION

Exhaust Valves
O = Normally open exhaust valve
E = Normally closed exhaust valve
X = Fixed flow exhaust valve
Supply Valves (provided with insulation)
C = Normally closed supply valve
S = Normally open supply valve
F = Fixed flow supply valve

VALVE ORIENTATION

H = Horizontal
U = Vertical upflow
D = Vertical downflow

CONTROL TYPE

C = Constant volume
P = Pneumatic
B = Base upgradable/pneumatic
F = Fixed, field adjustable (BEV, BSV only)

VALVE DESIGN

A = Conical shape diffuser (Accel II®)

VALVE OPTIONS

(As required, list alphabetically, then numerically)
B = Two single square flanges mounted on both ends of single body valves
F = One single square flange mounted on inlet of single body exhaust valves or discharge of single body supply valves
H = High wattage 24 Vdc solenoid valve, controlled by FHM510 monitor (BxV/PxV/"S" analog only)
I = High wattage 24 VAC solenoid valve, controlled by non-Phoenix device (BxV/PxV/"S" analog only)
L = Low wattage 24 VDC solenoid valve, controlled by IRM room monitor (BxV/PxV only)
P = Pressure switch (see note 2)
O = Power supply, valve-mounted, 120 V (see note 3)
T = Power supply, valve-mounted, 230 V (see note 3)
01-99 = Denotes factory-assigned special

VALVE CONTROLLER DESIGNATION

N = No electronics
F = Flow feedback (BEV, BSV only)
G = Two-state controller, flow feedback and high wattage 24 Vdc solenoid valve
T = Two-state controller and high wattage 24 Vdc solenoid valve

NOTES:

1. Accel II upgrades (AUG) are available to convert a BEV/BSV into an EXV/MAV control type N (pneumatic) valve.
2. Pressure switch set point = 0.3" wc (75 Pa).
3. Valve-mounted power supplies not available with CVV valves.

VALVE CONTROLLERS & OPTIONS

Valve Controller Designation

Flow feedback (F): Includes a circuit board installed on a Base series control valve to provide a 0-10 Vdc feedback signal scaled to indicate airflow.

Valve Options (components added to enhance a valve's functions)

Single square flange (F): Provides a single connection from a round single body valve to a square duct. On the inlet of single body exhaust valves; discharge of single body supply valves. Typically used in Neutralizer™ applications.

Solenoid valves (H, I, L): Installed on a two-position valve to pneumatically switch the valve between maximum and minimum flows.

Pressure switch (P): Detects low static pressure across the valve. Installed on non-hood exhaust valves to provide low static pressure alarm monitoring.

Power supply (O, T): Valve-mounted power supply provides +15 Vdc, -15 Vdc power to Phoenix Controls base upgradable valves with flow feedback.

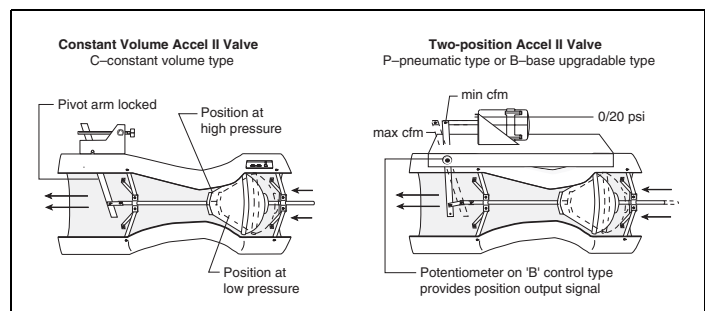

POINTS & WIRING (see submittal wiring diagram for project-specific details.)

Flow Feedback Option

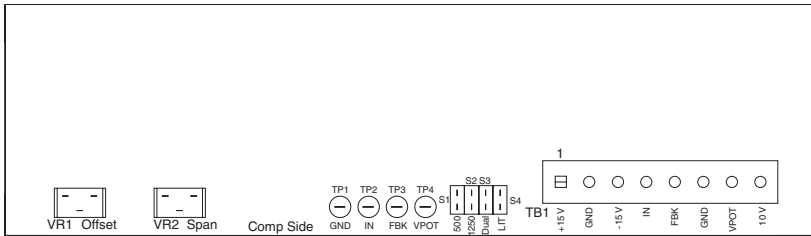

TERMINAL BLOCKS

Terminal Block	1	2	3	4	5	6	7	8
TB1	+15 V	Ground	-15 V	Slave input	Feedback	Ground	vPOT	10 V

Typical Wiring Diagrams

Hood Applications

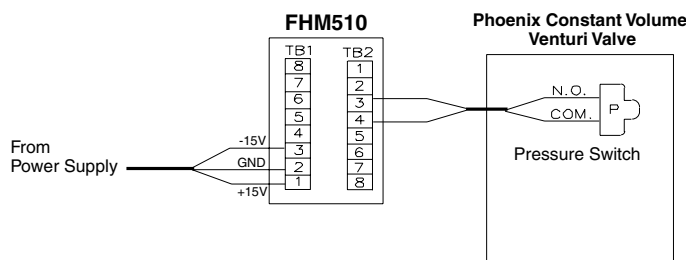

Flow Feedback

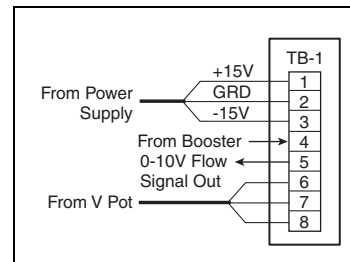

Constant Volume Application

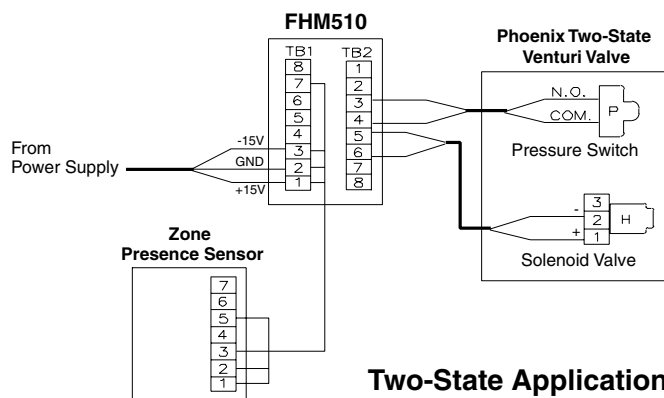

Two-State Application

NOTES:

1. Eight-conductor wire is Belden 9421 or equivalent.
2. Fume hood monitor enclosure must be earth grounded via the mounting hole ground straps.